

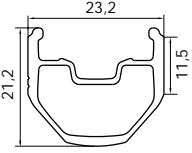

CROSSMAX™ ENDURO

USE : Use only on a cross-country MTB equipped with rim brakes. Any other use (such as on a tandem, road bike, cyclo-cross bike...) is strongly inadvisable, and is the sole responsibility of the user, which voids the Mavic warranty.

WHEEL WEIGHT WITHOUT SKEWER :
 Front : 785 g
 Rear : 935 g

WHEEL REF :
 Front : 323 353 10
 Rear : 323 354 13
 Pair : 323 424 14

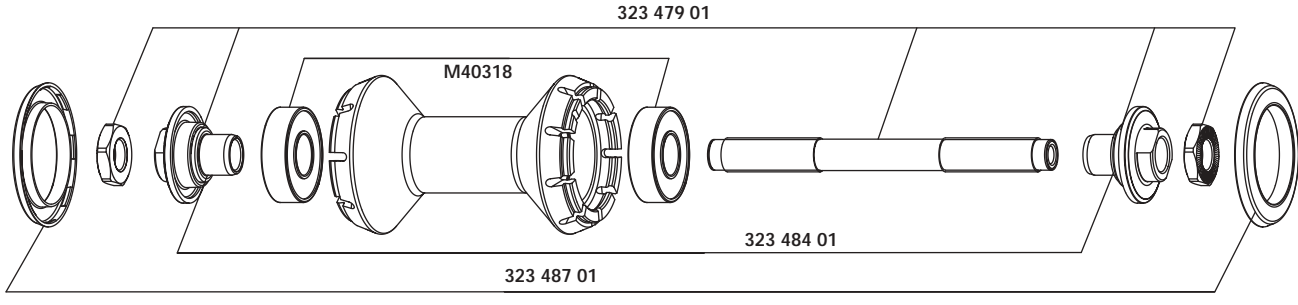
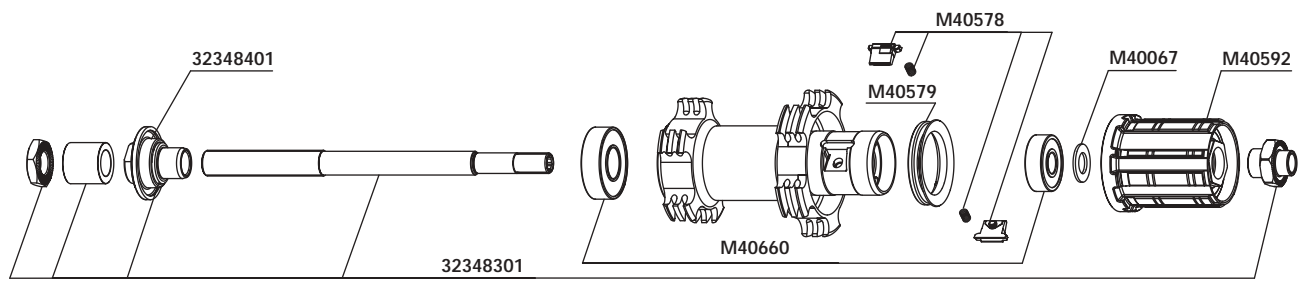
| | | |
|---|--|---|
| <p>RIMS</p> | <p>COMMERCIAL REFERENCES : do not use rim tape Front : 323 495 10 Rear : 323 495 13</p> | |
|  | <p>VALVE HOLE Ø Ø : 6,5 mm Length. : = 32 mm</p>  | <p>RECOMMENDED TIRE WIDTH AND PRESSURE</p> <p>Dimensions : Ø 26" only Compatible ETRTO 559 x 19 Recommended tire width : 1,00 - 2,30</p>  <p>Recommended tire pressure : See page 05</p> |
| <p>HUBS</p> | <p>MAINTENANCE : Clean with dry cloth or soap and water. Do not use pressurized water. Caution : The parts on the FTS-L free wheels (pawl assembly, springs, free wheel body) are not compatible with those on the FTS free wheels.</p> | |
|  | | |
|  | | |
| <p>WHEEL BUILDING</p> | <p>REFERENCE : Front : 323 438 01, length 258 mm (per 9) Rear : 323 439 01, length 279 mm (per 10)</p> | |
| <p>FEATURES : 1,8 - 2,0 black, round, double butted, stainless steel, straight pull spokes, with ABS type of nipples (self-locking).</p> | <p>LACING PATTERN : Front : Radial Rear : Crossed 3 on both sides</p> | <p>TENSION : Front : 100 - 120 kg Rear free wheel side : 110 - 130 kg</p> |
| <p>ACCESSORIES</p> | <p>WHEEL DELIVERED WITH :</p> | <p>MAINTENANCE</p> |
| <ul style="list-style-type: none"> • Front quick release skewer M40350 • Rear quick release skewer M40352 • UST valve M40495 • User guide and warranty card | | <ul style="list-style-type: none"> • Replacing the front axle See page 19 • Replacing the front bearings See page 19 • Replacing the rear axle See page 20 • Replacing the free wheel body See page 21 • Replacing the rear bearings See page 22 • Replacing a spoke See page 25 • Replacing the front rim See page 26 • Replacing the rear rim See page 27 |

WHEELS