

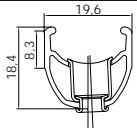

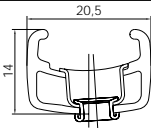

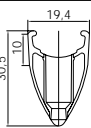

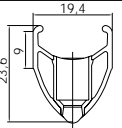



CLINCHER ROAD RIMS

TYPE		CLASSIC		PROFILED		
MODEL		OPEN PRO	MA	CXP 30	CXP 33	
RIM SECTION						
TECHNOLOGY						
RECOMMENDATIONS FOR USE		Road competition and training Cyclospor	All types of road use	Road competition and training Cyclospor - Triathlon	Road competition and training Cyclospor - Triathlon	
MATERIAL			6106	6106		
DIAM. OF VALVE HOLE AND VALVE HEIGHT		Ø 6,5 mm h = 32 mm		Ø 6,5 mm h ≥ 32 mm	Ø 6,5 mm h = 32 mm	
RECOMMENDED TIRE SECTION		18 to 23 mm	19 to 25 mm	18 to 23 mm	19 to 25 mm	
EYELETS		Double	Double	Profiled	Profiled	
AVERAGE WEIGHT Ø 700		435	460	550	470	
IN GRAMS Ø 650		395			432	
DRILLING Ø 700		28.32.36	32.36	28.32.36	28.32.36	
DRILLING Ø 650		32			28.32	
FINISH	HARD LAYER + CERAMIC	Ø 700 				
	HARD LAYER	Ø 700 - Ø 650 	MA 40 			
	MAVIC BLACK				Mavic black (Ø 700 et Ø 650)	
	BLUE FRANCE	Blue France Ø 700				
	RED				Red Ø 700	
	SILVER	Silver Ø 700			Silver	Silver Ø 700
	BRILLIANT		Brillant MA 2			
SPOKE NIPPLE	12 mm	12 mm	16 mm	14 mm		
LENGTH MATERIAL	Nickel-plated brass or anodized aluminum	Nickel-plated brass or anodized aluminum	Nickel-plated brass or anodized aluminum	Nickel-plated brass or anodized aluminum		
SPOKE SUPPORT DIAMETER		602 mm (Ø 700) 551 mm (Ø 650)	610 mm	584 mm	595 mm (Ø 700) 544 mm (Ø 650)	
RIM TAPE		Adhesive fabric rim tape 17,5 X 0,6 mm Polypropylene rim tape 17,5 X 0,5 mm				

CLINCHER ROAD OEM RIMS

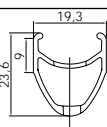
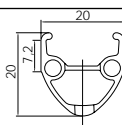
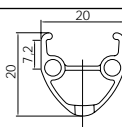
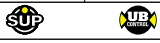
TYPE		PROFILED		
MODEL		CXP 23	CXP 21	CXP 11
RIM SECTION				
TECHNOLOGY				
DIAM. OF VALVE HOLE		6,5 mm	6,5 mm	6,5 mm
VALVE HEIGHT		32 mm	32 mm	32 mm
TIRE SECTION		18 to 23 mm	18 to 23 mm	18 to 23 mm
SPOKE NIPPLE	LENGTH	14 mm	12 mm	12 mm
	MATERIAL	Nickel-plated brass (alu not recommended)	Nickel-plated brass (alu not recommended)	Nickel-plated brass (alu not recommended)
DIAMETER AND SPOKE SUPPORT		595 mm	598,5 mm	598,5 mm