

PEDALING CADENCE KIT HOME TRAINER KIT

USE: Use only on a Cross Country or Cross Mountain MTB, a tandem or an Asphalt type of bike. Any other use (such as on an Extreme MTB, Cyclo-Cross bike...) is strongly inadvisable, is the sole responsibility of the user and voids the Mavic warranty.
The Home-Trainer Kit is designed for INDOOR use only.

WEIGHT:
Pedaling cadence sensor: 18 g
Home Trainer sensor: 22 g

REFERENCES:
Pedaling cadence kit: 323 596 01
Home Trainer kit: 323 597 01

SPARE PARTS

PEDALING CADENCE SENSOR

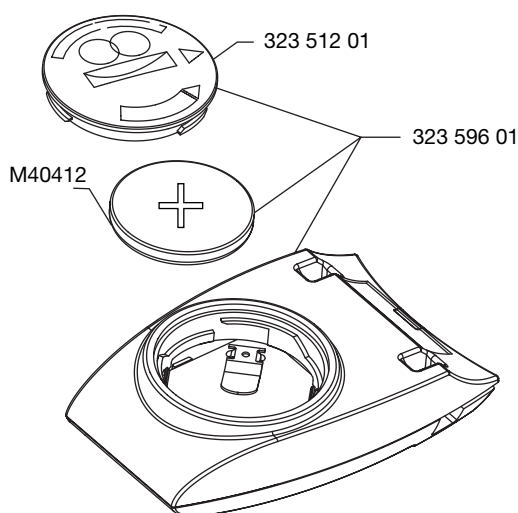

HOME TRAINER SPEED SENSOR

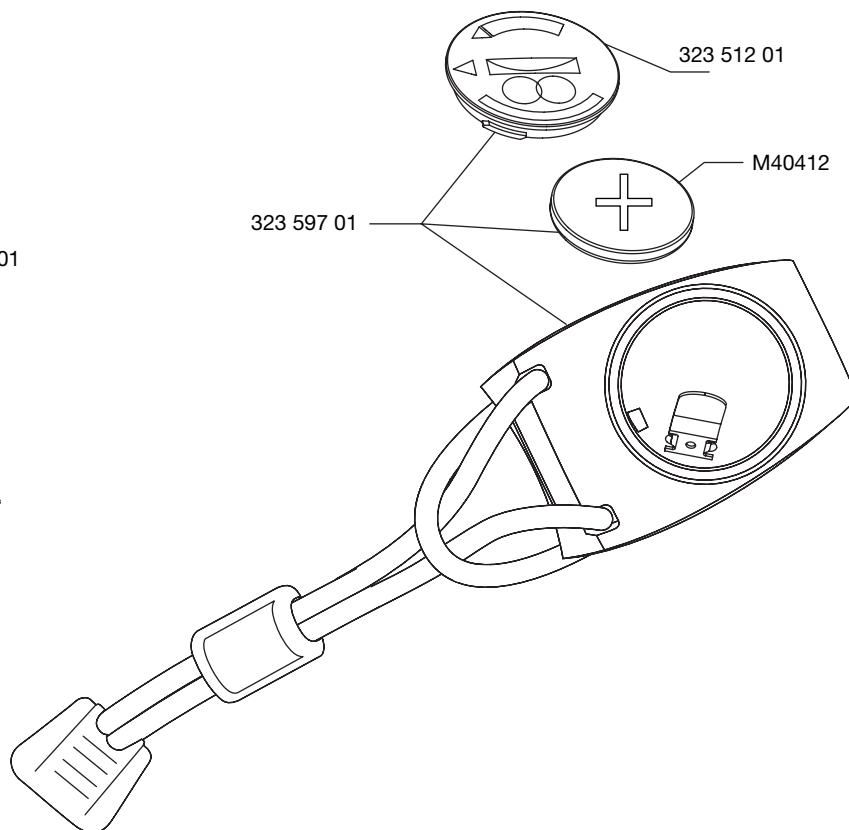

MAINTENANCE: Clean with dry cloth or soap and water. Do not use pressurized water.
Do not store near a window exposed to the sun for a long period of time.

REFERENCES OF ACCESSORIES

Fixing ties: M40390, pack of 50 ties
Wheel magnet bracket: M40540
Crank magnet: 323 510 01

FUNCTIONING FEATURES

Power supply: battery CR2032 (pedaling cadence sensor and Home Trainer sensor)
Water resistance: Resistant to rainwater. Avoid total immersion of the electronic components and do not use pressurized water. The Home Trainer kit is only to be used indoors.

Maximum transmission distance: Cadence sensor: 70 cm
Home Trainer sensor: 85 cm
Operating temperature range: -10 to + 50°C / 14 to 122°F
Speed: up to 99.9 km/h or m/h
Cadence: up to 180 revs / min

INSTALLATION, USE AND PROGRAMMING

- **Installing the cadence sensor** See 2004 technical manual, page 43
- **Installing the Home Trainer sensor** See page 42
- **Digital synchronization** See page 42